



R66

N X G



R66
N X G

PREMIUM UPGRADES, ACCESSIBLE PRICING

NxG is the next generation of the industry's best-selling light single turbine. Now equipped with an all-glass cockpit, impact-resistant windshield, 2-axis Garmin autopilot standard, and improved styling under the NxG trims.

Fitted with a powerful Rolls-Royce RR300 turbine engine, it's the perfect balance of style and rugged practicality—at the most attainable price in its class.

INTERIOR

All new materials are available on the R66 NxG. This upgraded interior moves to a more upscale appearance in three new colors including a standard Stone on the Southwood trim and a choice of lighter Sand or Graphite for the mid Palo Verde Trim.

- **Redesigned Trim Structures and Paint Schemes:** Available with three new trim options for increased personalization
- **All-Glass Cockpit:** Replaces traditional round gauges with advanced digital displays. Engine and system instruments are now provided on the Garmin TXi flight display
- **Autopilot:** Industry first light helicopter with a standard 2-axis Garmin autopilot with enhanced safety features like limit cueing, single button level mode, hover assist, overspeed and under speed protection
- **Upgraded Interior:** Features premium upholstery, incorporating high-quality finishes



Detail photos are Riviera edition.

ENHANCED EXTERIOR DESIGN

- Updated paint palette, including more metallic and standard colors
- Polycarbonate impact-resistant windshield
- New exterior LED landing lights for enhanced visibility during nighttime operations, with a pulse mode for further bird strike avoidance



CHOOSE YOUR TRIM



RIVIERA EDITION

- Limited edition, only available for the next twelve months
- Advanced Garmin avionics
- 3-axis Garmin autopilot
- Exclusive Midnight + Umber interior, featuring premium materials and design



PALO VERDE

- Garmin G500H 700P/700P TXi or an optional 1060/700P TXi flight display as well as Garmin GTN 750Xi GPS/COM/NAV
- 2-axis Garmin autopilot
- All-glass cockpit with sun visors and glare shield



SOUTHWOOD

- Garmin G500H 700P/700P TXi flight display
- 2-axis Garmin autopilot
- Interior available in Stone or Graphite
- Impact-resistant windshield
- New LED landing lights

Helicopter	R66 NxG
Engine	Rolls-Royce RR300 Turbine
Horsepower	300 shp turboshaft; derated to 270 shp takeoff & 224 shp continuous
Maximum Gross Weight	2700 lb (1225 kg)
Approximate Empty Weight (Including Oil & Std Avionics)	1290 lb (585 kg)
Fuel Capacity / Weight	73.6 gal / 493 lb (224 kg)
Pilot, Passengers, and Baggage (with Maximum Fuel)	917 lb (416 kg)
Maximum Airspeed (Vne) at Maximum Gross Weight	130 kts (240 km/h)
Cruise Speed at Maximum Gross Weight	up to 110 kts (204 km/h)
Maximum Range (No Reserve)	approx 350 nm (650 km)
Hover Ceiling IGE at Maximum Gross Weight	over 10,000 ft
Hover Ceiling OGE at Maximum Gross Weight	over 10,000 ft
Rate of Climb	over 1000 fpm
Maximum Operating Altitude	14,000 ft
Electrical System	28 volt

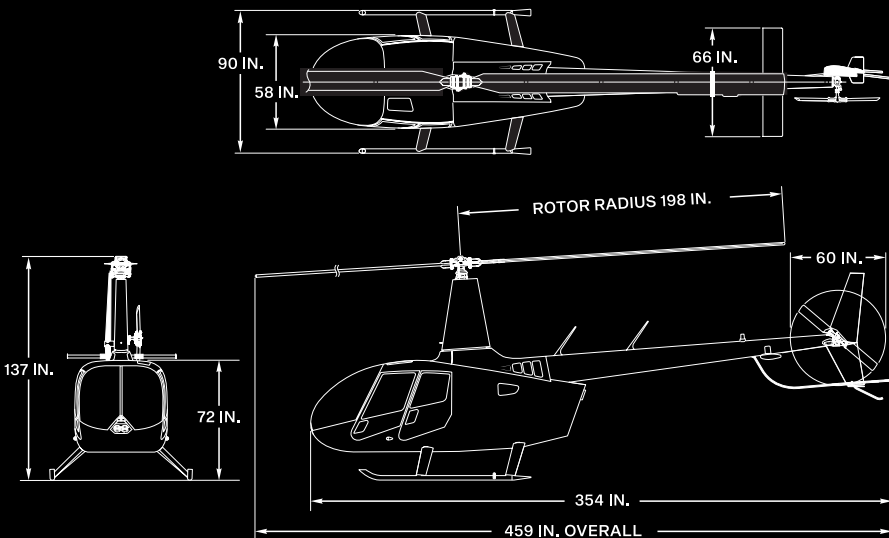

CLIMB HIGHER

Experience the R66 NxG.
Contact your local Robinson Helicopter dealer today.

2901 Airport Drive
Torrance, CA 90505 USA
www.robinsonheli.com
310-539-0508



© Robinson Helicopter Company. Robinson and R66 are registered trademarks of Robinson Helicopter Company. All other trademarks or registered trademarks are property of their respective companies. (Oct. 2025)