



R44  
Raven II

R44

A red Robinson R44 helicopter is shown from a high-angle, top-down perspective, flying over a dense, dark green forest. The helicopter's main rotor blades are blurred, showing a yellow and white striped pattern. The tail rotor is also visible, and the registration number 'N461' is printed on the tail boom. The cockpit is visible, showing two seats. The overall scene is dynamic and emphasizes the helicopter's performance in a natural setting.

**R44**

## **VERSATILITY IN ACTION**

Ideal for just about any application, the R44 is available in five configurations: Cadet, Raven I, Raven II, Clipper I, and Clipper II. Across them all, our patented cyclic design enhances safety, comfort, and ease of operation.

Featuring hydraulically boosted controls, a lightweight, sturdy frame, roomy cabin and two engine offerings (Lycoming's O-540 carbureted in the Cadet/Raven I/Clipper I; and the IO-540 fuel injected in the Raven II/Clipper II), the R44 is versatile, reliable, easy to maintain, and inexpensive to own and operate.

# POWER. PERFORMANCE. PRACTICALITY.

- Excellent reliability, responsive handling, and altitude performance make R44 helicopters ideal for private, business, and utility applications
- Powered by proven Lycoming engines with unrestricted starts
- Spacious cabin, generous legroom, and panoramic windows enhance comfort and visibility
- R44 Clipper variants offer either fixed utility floats or pop-out floats for confident over-water operation



## SAFETY FEATURES

- 4K cockpit camera and robust fuel system prioritize occupant well-being
- Crashworthy fuel system minimizes leakage risk, enhancing overall safety
- Optional: Autopilot and bird-strike-resistant windshields highlight Robinson's continual commitment to safety improvements

## DISTINCTIVE DESIGN

- Standard instruments and optional glass avionics from Garmin provide clear information and intuitive operation
- Strategically arranged instruments and ergonomic controls ensure precise handling in all conditions
- Configure the information display to your preference and focus on the joy of flying



## PERSONALIZATION OPTIONS

- Leather seats in tan, gray, or charcoal
- Air conditioning for enhanced comfort in any climate (only available on Raven II & Clipper II)
- Bubble windows
- Heated seats for added warmth in colder weather
- Bose A30 headsets for superior audio clarity and noise cancellation



## OWNERSHIP & MAINTENANCE

- Spend more time flying and less time managing logistics
- Life-limited components with 2200-hour or 12-year service lives reduce maintenance costs
- 50-hour oil changes; engine and airframe have TBOs of 2200 hours or 12 years, whichever comes first
- The two-bladed rotor system minimizes hangar space requirements

## UNMATCHED WARRANTY & SUPPORT

- Two-year or 1000-hour limited aircraft warranty for peace of mind
- Robinson's comprehensive support network ensures you're always well-equipped to fly with confidence



| Helicopter  | R44 Raven II • Clipper II  | R44 Raven I • Clipper I • Cadet                     |
|---|--|---|
| Engine  | Lycoming IO-540, six cylinder, fuel injected                                   | Lycoming O-540, six cylinder, carbureted            |
| Horsepower  | derated to 245 hp takeoff & 205 hp continuous                                  | derated to 225 hp takeoff & 205 hp continuous       |
| Maximum Gross Weight                                    | 2500 lb (1134 kg)  | 2400 lb (1089 kg)                                   |
| Approximate Empty Weight (Including Oil & Std Avionics) | 1505 lb (683 kg) • 1560 lb (712 kg) • 1575 lb (715 kg)                         | 1450 lb (658 kg) • 1500 lb (680 kg)                 |
| Standard Fuel Capacity / Weight                         | 29.5 gal capacity / 177 lb (80 kg)   | 29.5 gal capacity / 177 lb (80 kg)                  |
| Auxiliary Fuel Capacity / Weight                        | 17.0 gal capacity / 102 lb (46 kg)   | 17.0 gal capacity / 102 lb (46 kg)                  |
| Pilot, Passengers, and Baggage (with Standard Fuel)     | 818 lb (371 kg) • 763 lb (342 kg) • 748 lb (340 kg)                            | 773 lb (351 kg) • 723 lb (328 kg)                   |
| Maximum Airspeed (Vne) at Maximum Gross Weight          | 120 kts (223 km/h) • 110 kts (204 km/h) • 120 kts (223 km/h)                   | 120 kts (223 km/h) • 110 kts (204 km/h)             |
| Cruise Speed at Maximum Gross Weight                    | up to 109 kts (202 km/h) • up to 102 kts (196 km/h) • up to 109 kts (202 km/h) | up to 108 kts (200 km/h) • up to 101 kts (187 km/h) |
| Maximum Range (No Reserve)                              | approx 300 nm (550 km)   | approx 300 nm (550 km)                              |
| Hover Ceiling IGE at Maximum Gross Weight               | 8950 ft at 2500 lb   | 6400 ft at 2400 lb                                  |
| Hover Ceiling OGE at Maximum Gross Weight               | 4500 ft at 2500 lb   | 2000 ft at 2400 lb                                  |
| Hover Ceiling OGE at 2300 lb                            | 7500 ft at 2300 lb   | 4000 ft at 2300 lb                                  |
| Rate of Climb   | over 1000 fpm  | over 1000 fpm                                       |
| Maximum Operating Altitude                              | 14,000 ft  | 14,000 ft   |
| Electrical System                                       | 28 volt  | 28 volt   |

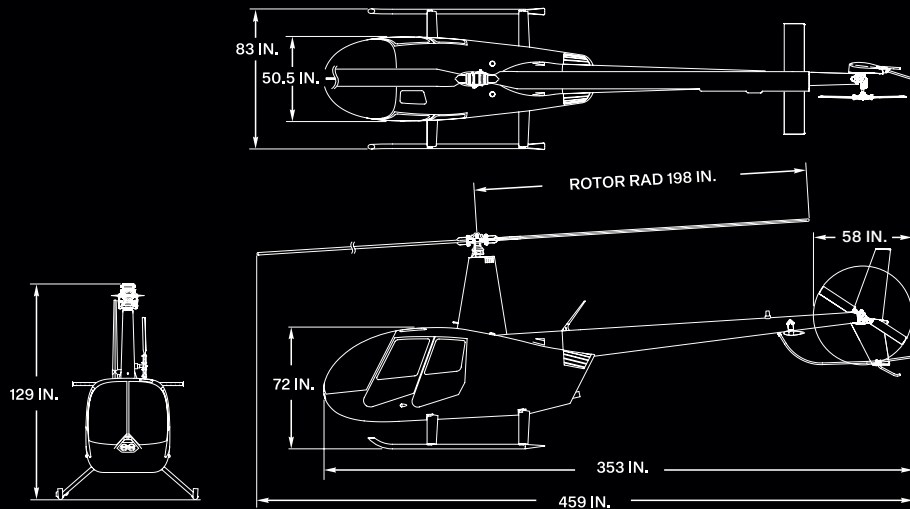

## CLIMB HIGHER

Experience the R44 Helicopters.  
Contact your local Robinson Helicopter dealer today.

2901 Airport Drive  
Torrance, CA 90505 USA  
[www.robinsonheli.com](http://www.robinsonheli.com)  
310-539-0508



© Robinson Helicopter Company. Robinson and R44 are registered trademarks of Robinson Helicopter Company. All other trademarks or registered trademarks are property of their respective companies. (October 2025)